

**SIDE VIEW**

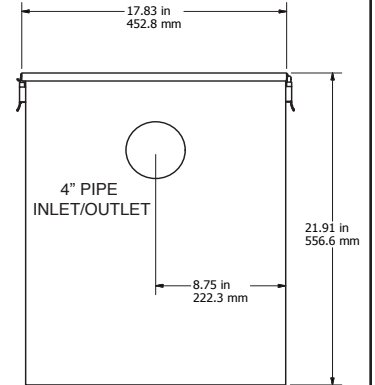

**END VIEW**

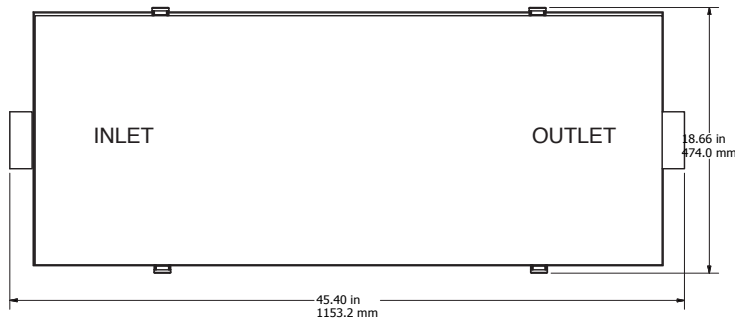

**TOP VIEW**

### **FEATURES:**

- Constructed of corrosion resistant materials suitable for installation in virtually any location. Attractive sanitary Stainless Steel exterior.
- Single piece lid latches into place using quick-release stainless steel lid clamps.
- Compact footprint.
- Two (2) No-Hub Connectors provided.

### **TECHNICAL DATA**

Materials: \_\_\_\_\_ Exterior: 304 Stainless Steel, Bright Finish  
Interior: Rotationally Molded Polyethylene

Maximum Inlet Flow Rate: \_\_\_\_\_ 75 GPM (4.73 l/s)

Grease Retention Capacity: \_\_\_\_\_ 168.95 Pounds (76.63 Kg)

## INSTALLATION INFORMATION

### Suggested Minimum Footprint Dimensions

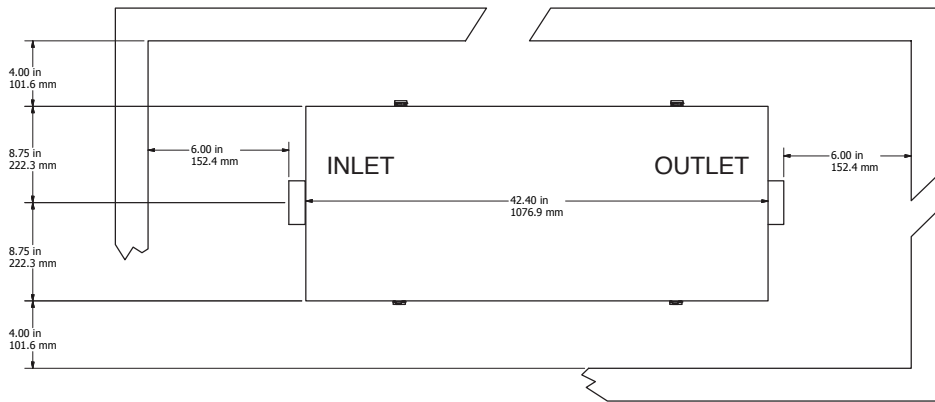

### Requirements

Allow a minimum of 6" clearance from top of tank for removal of unit lid and maintenance.

READ instruction manual included with system before doing anything.

Install unit allowing for the minimum clearances shown.

Make piping connections with rubber "No Hub" connectors (provided).

Keep outlet piping as straight as possible. Use only "sweep" connections.

Install vent on outlet piping.

**DON'T . . .** Install "P" trap on outlet connection of tank. (Note: the unit already has an internal gas trap).  
Reduce pipe size on outlet piping.

NOTE: Drawing for reference only. Equipment must be installed in compliance with all applicable laws, regulations and codes, including plumbing codes. Installation should be performed by a qualified plumber.

### Job Specification:

Grease and oils separator(s) shall be Thermaco **Big Dipper Passive** Hydromechanical as manufactured by Thermaco, Inc., Asheboro, North Carolina as noted on plans.

### Separator Specifications:

Furnish and install \_\_\_ Thermaco **Big Dipper Passive** Model No. LD-500, bright finish type 304 stainless steel exterior, rotationally molded polyethylene interior passive hydromechanical grease interceptor(s) for floor mounted or partially recessed installation, rated at 75 gallons per minute (4.73 l/s) peak flow, 168.95 Pounds (76.63 Kg) of grease capacity and including as an integral part of the unit, an integral flow control device, an integral gas trap, quick release stainless steel lid clamps, and a gasketed and fully removable 304 stainless steel lid. Two (2) no-hub connectors for plumbing connection provided.